

Figure 1: Side And Top View Of Yanmar SD 40 or SD 50 Saildrive

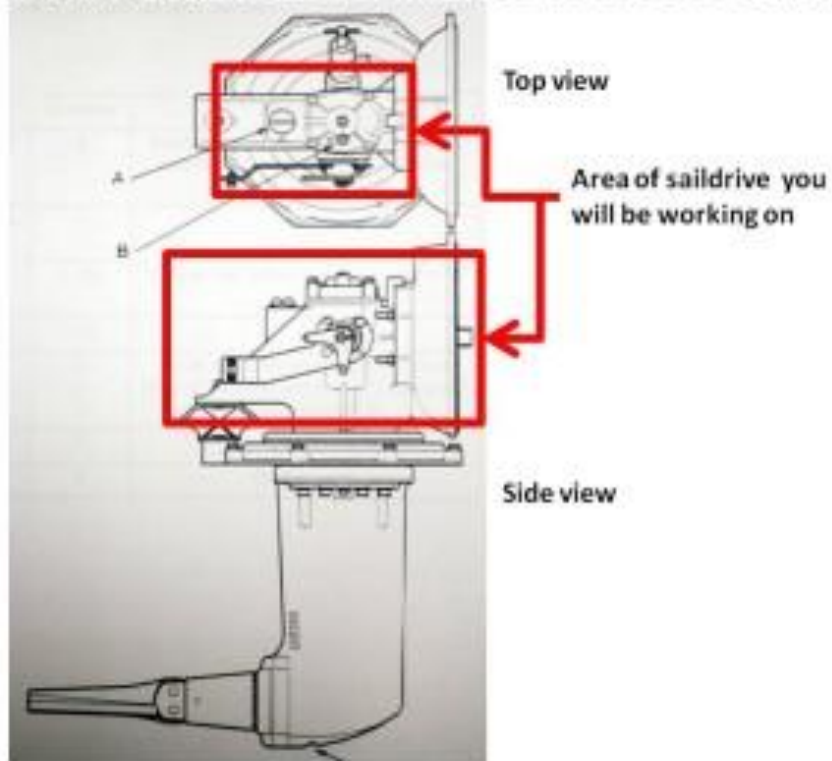

Figure 2: Close-up View Of What You Will Be Working On

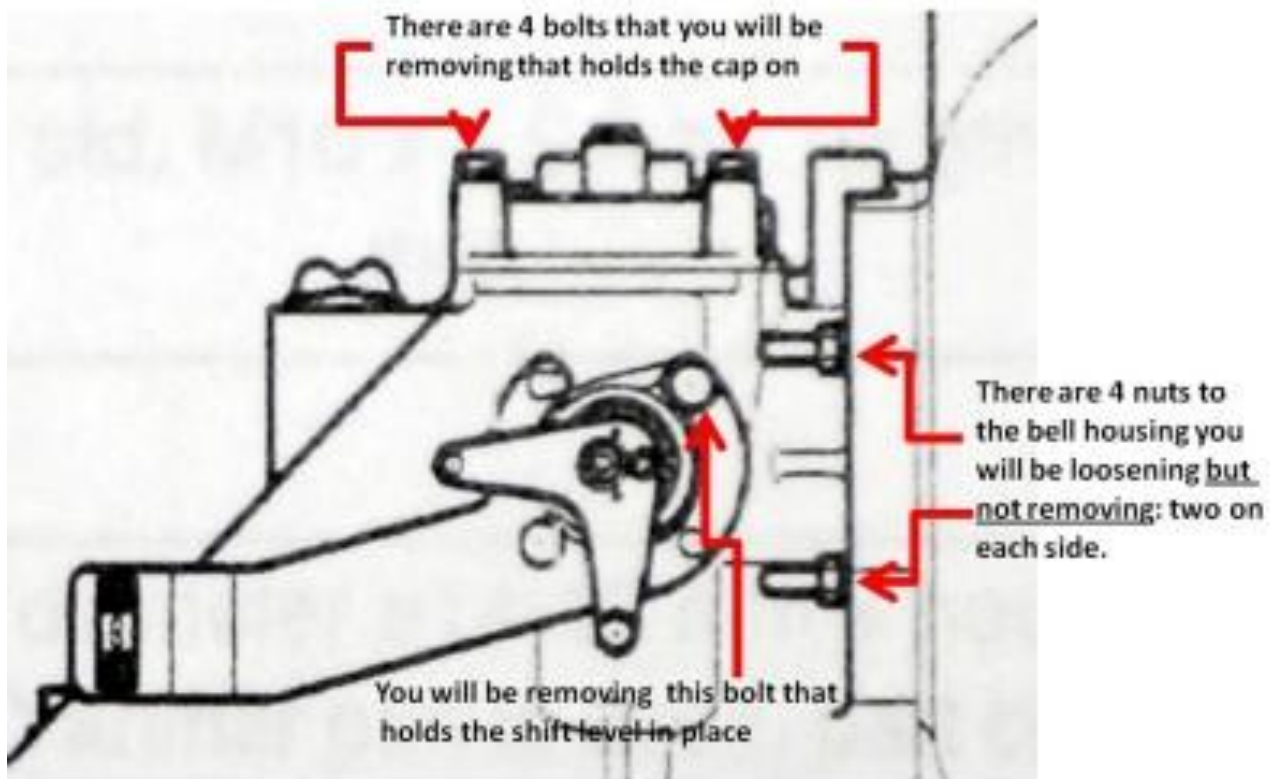

Figure 3: Step 1: Remove Upper Gear Tightening Bolts (4) And Upper Gear Cover

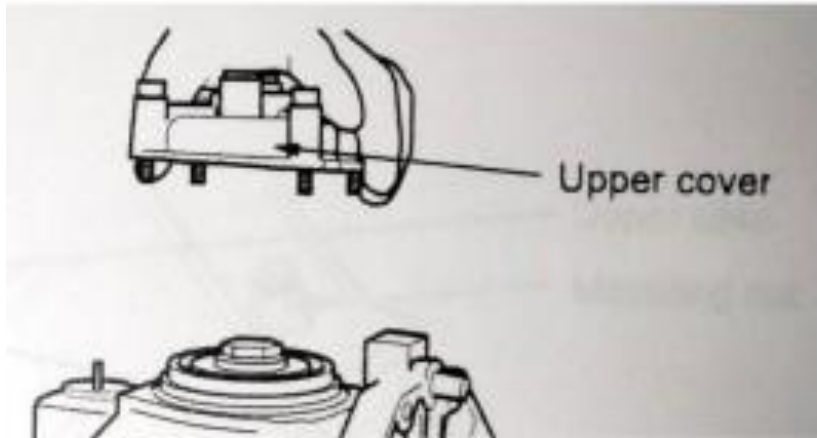
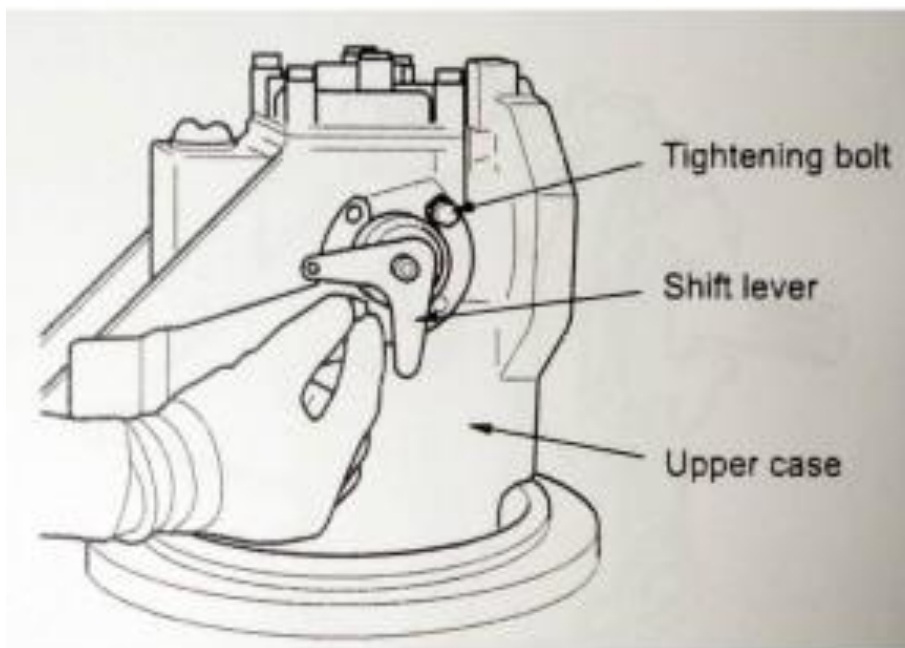
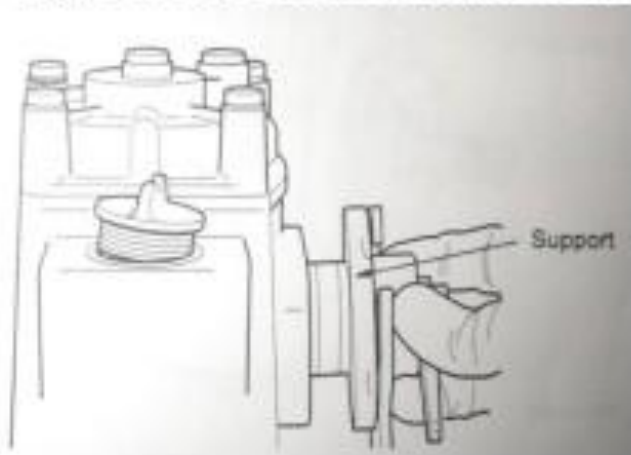

Figure 4: Step 2 Remove Shift Lever Assembly



Remove the shift lever Assembly tightening bolt

Figure 5: Step 2 Remove Shift Lever Assembly, Con't.



Once the bolt is removed, carefully pull out the shift lever assembly. Be careful when you do as a spring will help push the assembly out.

As you pull the assembly out, make sure you note the angle the shifter is at. When you reinsert the assembly, the shifter will need to be at the same angle that it came out at.

I plan on placing a mark on the side of the housing to note the position of the shifter when I pull it out. This will tell me how to position the shifter when I reassemble it.

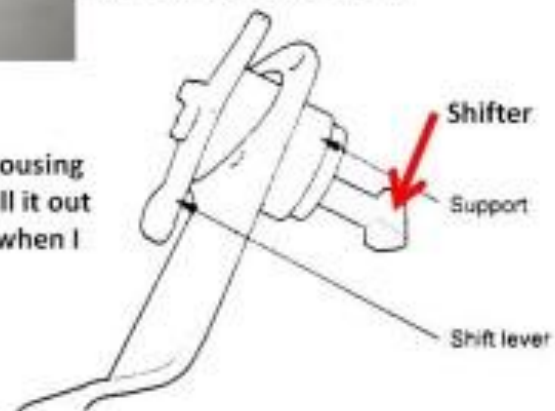

Figure 6: Step 3 Loosen Bell Housing Nuts And Push Pinion Gear And Shaft Back

This is where you need to pay attention and not do something stupid like what I would do.

The pinion gear is what transfers the engine's torque to the saildrive and is inside the bell housing

This figure has the bell housing removed and shows the pinion shaft assembly. Normally, the mechanic will separate the engine from the saildrive, back the engine off about six inches and back this pinion gear and shaft off. However, you are smarter than that! Instead, you need to only loosen the nut that is on each of the 4 stud bolts and back them off until they are just at the end of each stud bolt. **DO NOT REMOVE THE NUTS FROM THE STUD BOLTS.** Next, using a hammer, gently tap each bolt to move the pinion gear assembly back a bit so you can easily remove the drive cone assembly (see next figure).

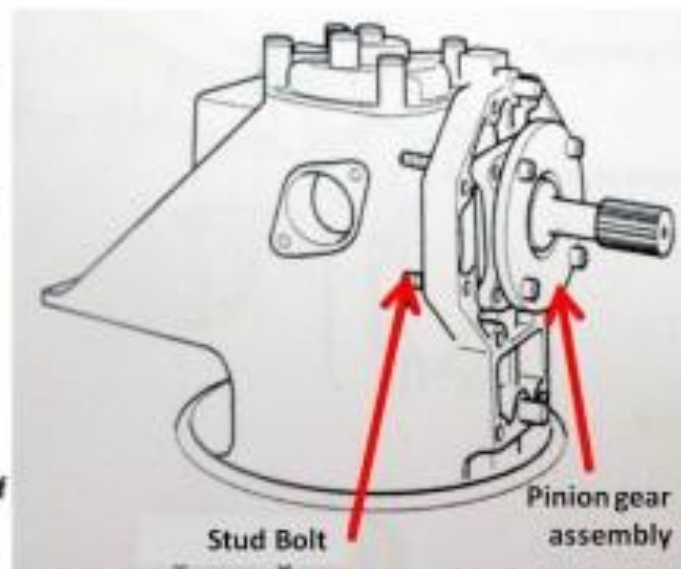
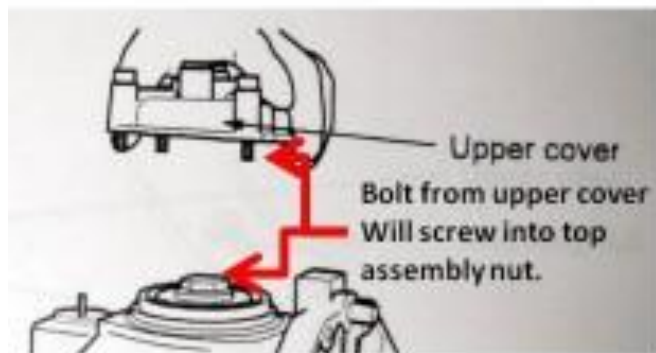

Figure 7: Step 4 Remove The Drive Cone Assembly



The figure to the left shows the exposed top part of the drive cone assembly once you remove the cap. Note the assembly nut at the top of the drive cone assembly that is still sitting in the gear housing. It is threaded at the top so you can screw one of the bolts from the upper cover into the nut at the top of the drive cone assembly to lift it out.

If you like, you can purchase a special Yanmar tool to lift this assembly out.

However, as noted above, if you just take one of the bolts from the upper cover, you can use it to screw it into the nut at the top of the drive cone assembly nut. Then you can use some vice grips to grab the bolt and lift the assembly out.

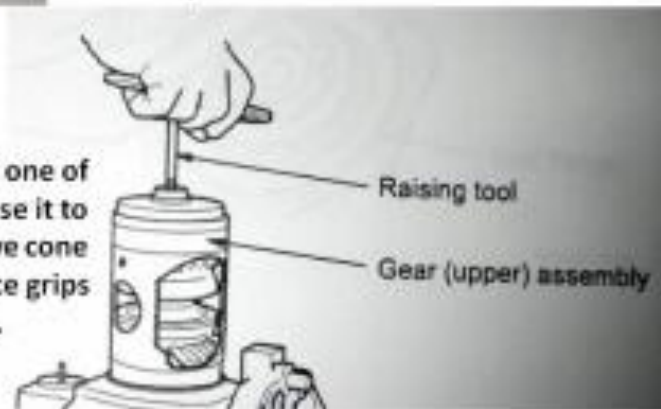

Figure 8: Step 5 Disassembling The Drive Cone Assembly



This is what the drive cone assembly looks like once it is removed.

Once you have removed the drive cone assembly you need to insert the clutch shaft into a spline socket so you can insert the socket into a vice without damaging the splines on the shaft. I am not sure what size of spline socket you need but you can buy a universal spline socket set from Sears for under \$40. Or, you can buy Yanmar's special tool A but it is very expensive.

Once the assembly is inserted in the spline socket and you have tightened down the vice, place a wrench on the top nut (it is left handed).

You may need to place the wrench handle into a pipe to get extra leverage to remove the nut.

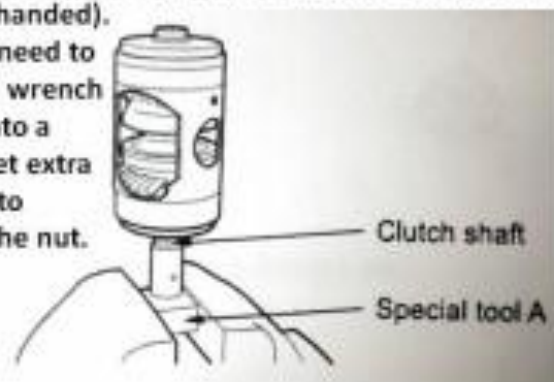

Figure 9: Step 5 Disassembling The Drive Cone Assembly, Con't.

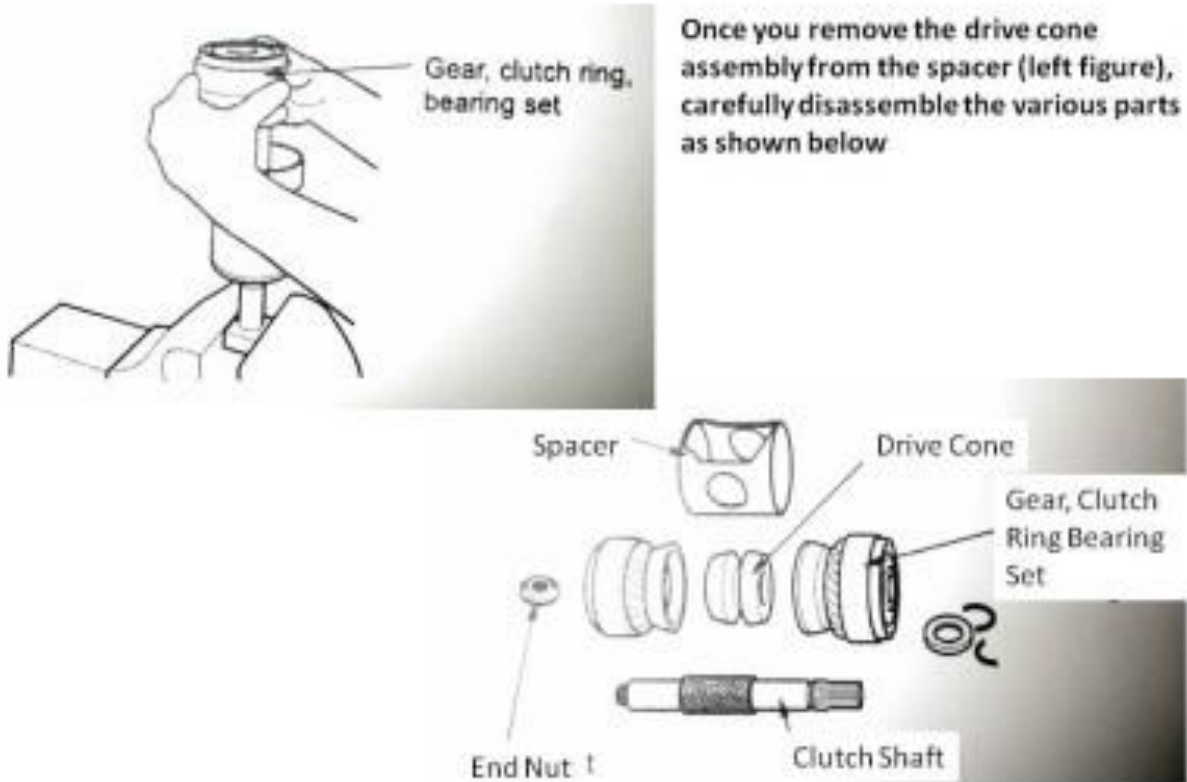

Figure 10: Step 6 Inspecting The Drive Cone And Gear

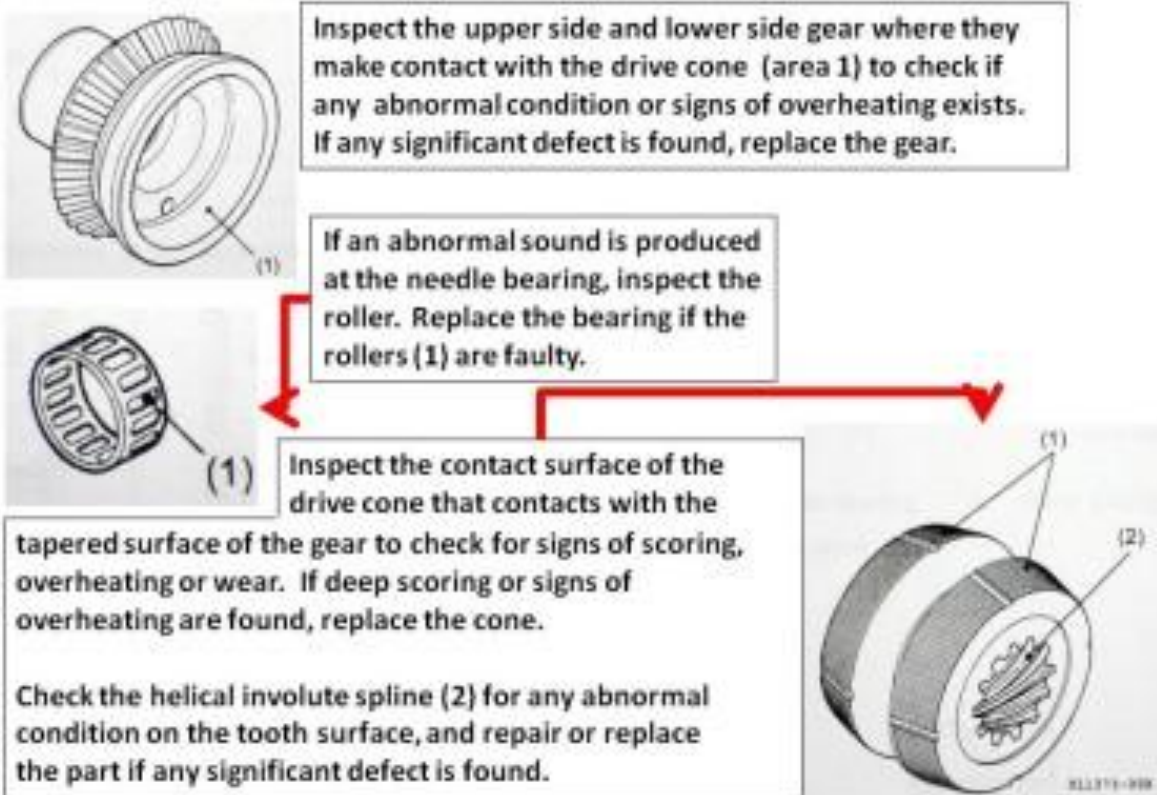

Figure 11: Step 7 Lapping Procedure For Drive Cone

Coat the lapper powder onto the cave of the clutch gear (use 67 micron silicon carbide #280, or gear paste).



Set the gear on the clutch shaft with a needle bearing and then set the drive cone on the clutch shaft.



Lap the gear's cave and drive cone, pushing them together by hand.



Next, push and turn the gear about 5 times both clockwise and counterclockwise.

Figure 12: Step 7 Lapping Procedure For Drive Cone, Cont.

After lapping them, wash them with kerosene or similar solvent. They need to be washed thoroughly so no grit is present.

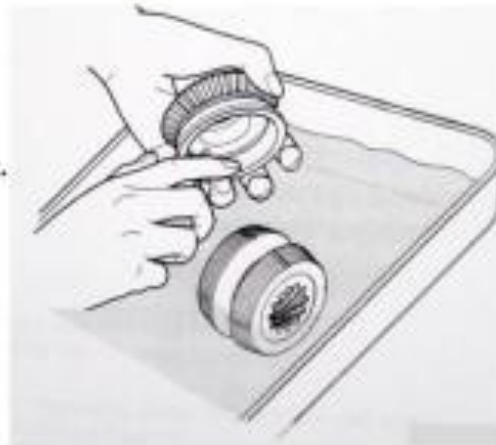

When assembling the drive cone, be sure to check its alignment. The larger diameter 044 face should be on the lower gear side.

